

2

2

PROJECT NO:

HWY: CTH MS (UNIVERSITY AVE)

COUNTY: DANE

PLAN VIEW

SHEET NO-1

E

BY: J. J. WINE

BY: J. J. WINE

BY: J. J. WINE

DATE: 10/15/10

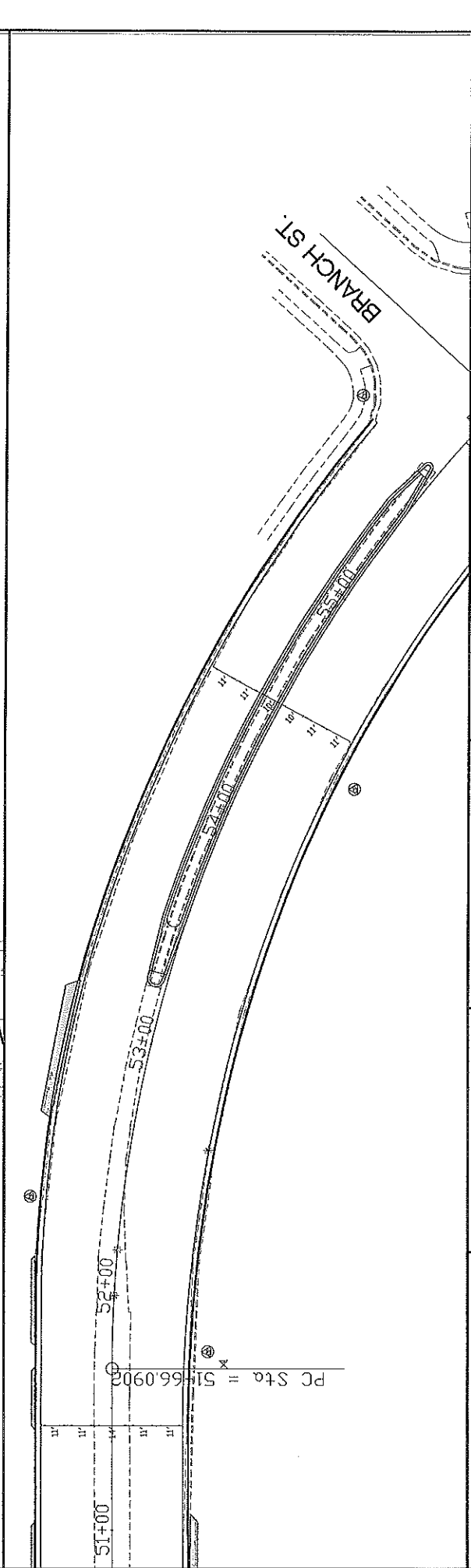
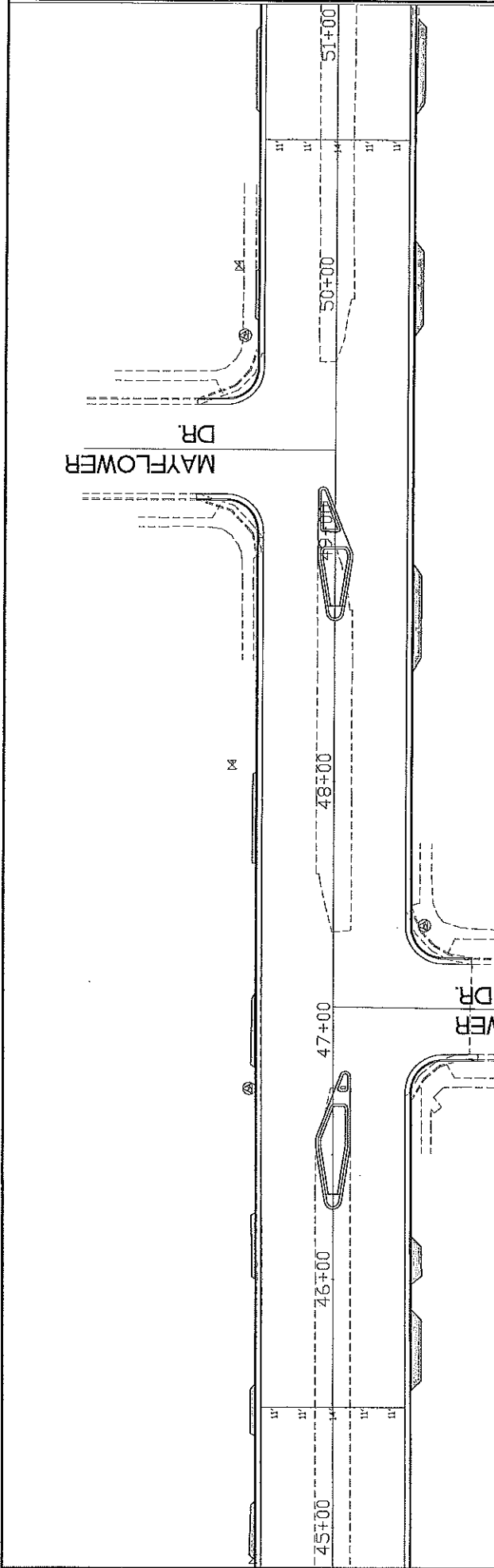

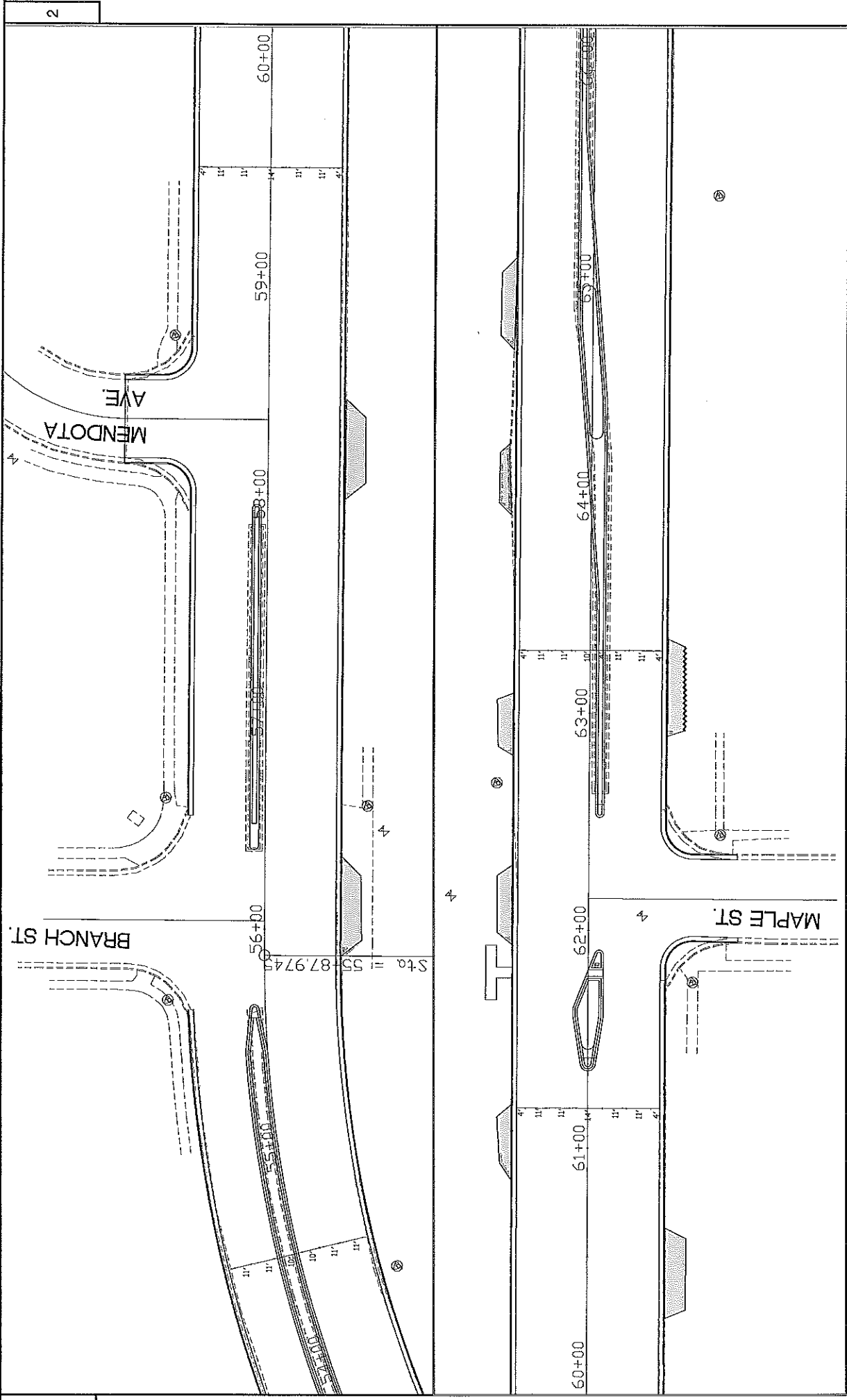

2

2

PROJECT NO:

HWY: CTH MS (UNIVERSITY AVE)

COUNTY: DANE

PLAN VIEW

SHEET NO: 3

E

DATE: 08/20/2018 10:48:00 AM
 DRAWN BY: J. WILSON
 CHECKED BY: M. HARRIS
 PROJECT: CTH MS (UNIVERSITY AVE) - RAMP AND BRIDGE
 COUNTY: DANE
 SHEET NO: 3
 E

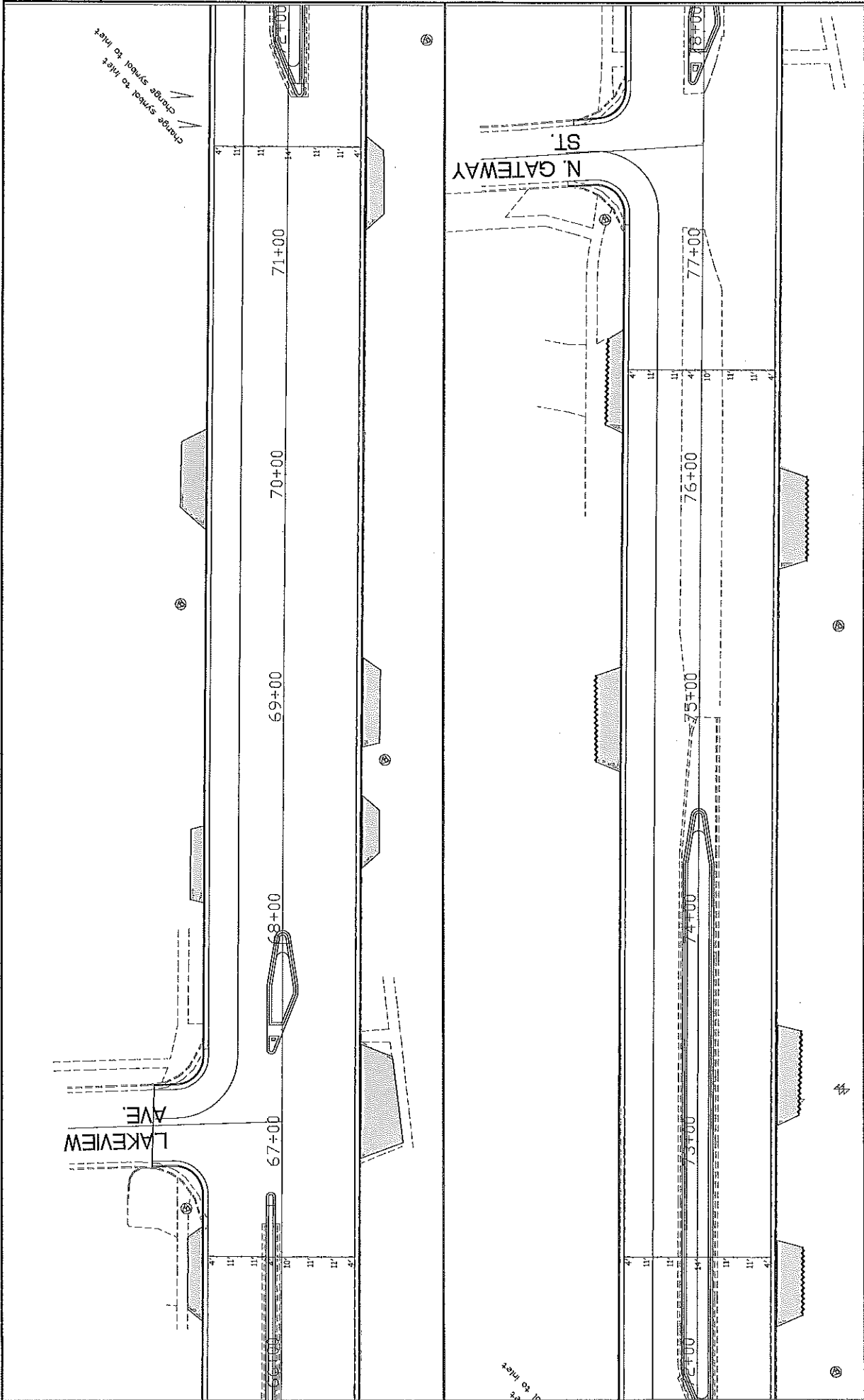

BY THE STATE OF WISCONSIN
 IN THE YEAR 1984
 COUNTY OF DANE
 CITY OF MADISON
 ENGINEER: [Signature]

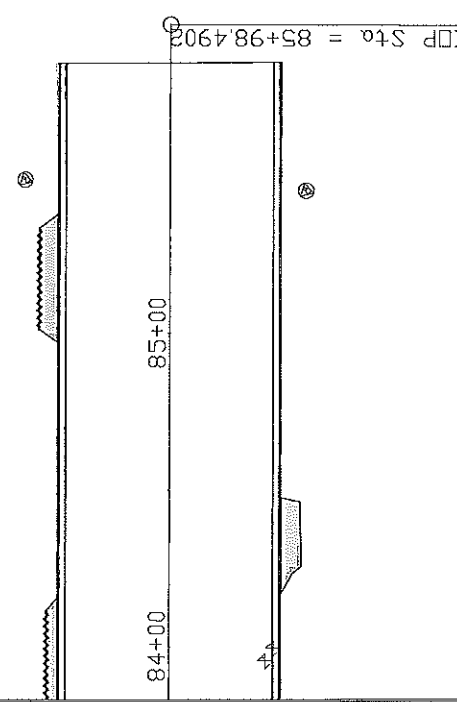
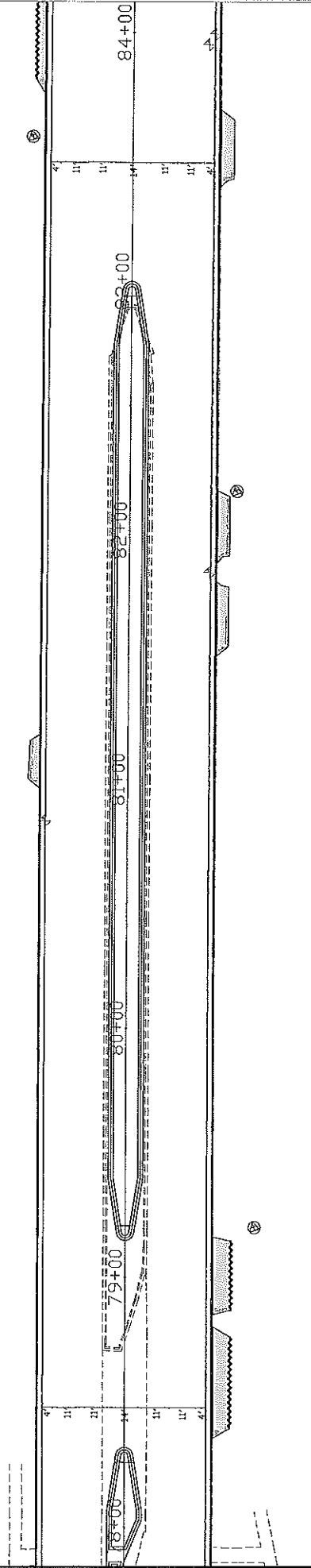

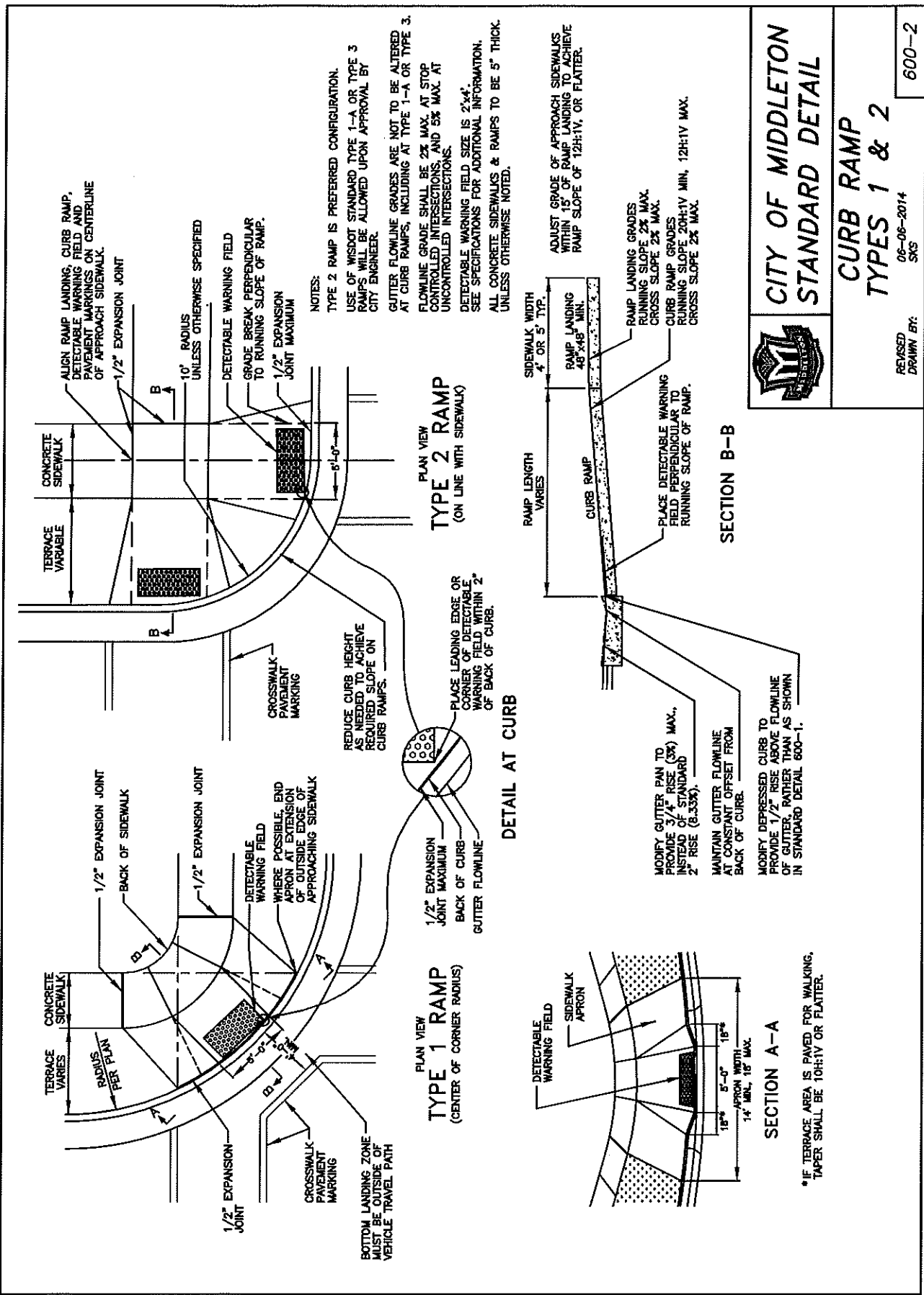

NOTES:

- TYPE 2 RAMP IS PREFERRED CONFIGURATION.
- USE OF WSDOT STANDARD TYPE 1-A OR TYPE 3 RAMPS WILL BE ALLOWED UPON APPROVAL BY CITY ENGINEER.
- GUTTER FLOWLINE GRADES ARE NOT TO BE ALTERED AT CURB RAMPS, INCLUDING AT TYPE 1-A OR TYPE 3.
- FLOWLINE GRADE SHALL BE 2% MAX. AT STOP CONTROLLED INTERSECTIONS, AND 5% MAX. AT UNCONTROLLED INTERSECTIONS.
- DETECTABLE WARNING FIELD SIZE IS 2'x4'.
- SEE SPECIFICATIONS FOR ADDITIONAL INFORMATION.
- ALL CONCRETE SIDEWALKS & RAMPS TO BE 5" THICK, UNLESS OTHERWISE NOTED.

CITY OF MIDDLETON

STANDARD DETAIL

CURB RAMP

TYPES 1 & 2

REVISED
DRAWN BY: SKS

06-06-2014

600-2

* IF TERRACE AREA IS PAVED FOR WALKING, TAPER SHALL BE 10H:1V OR FLATTER.

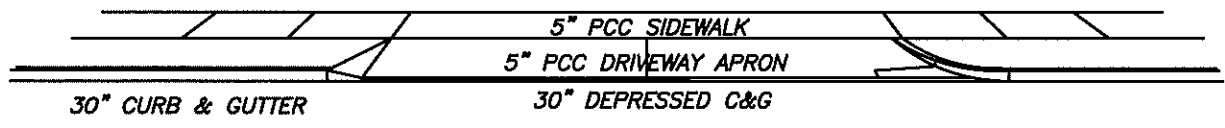
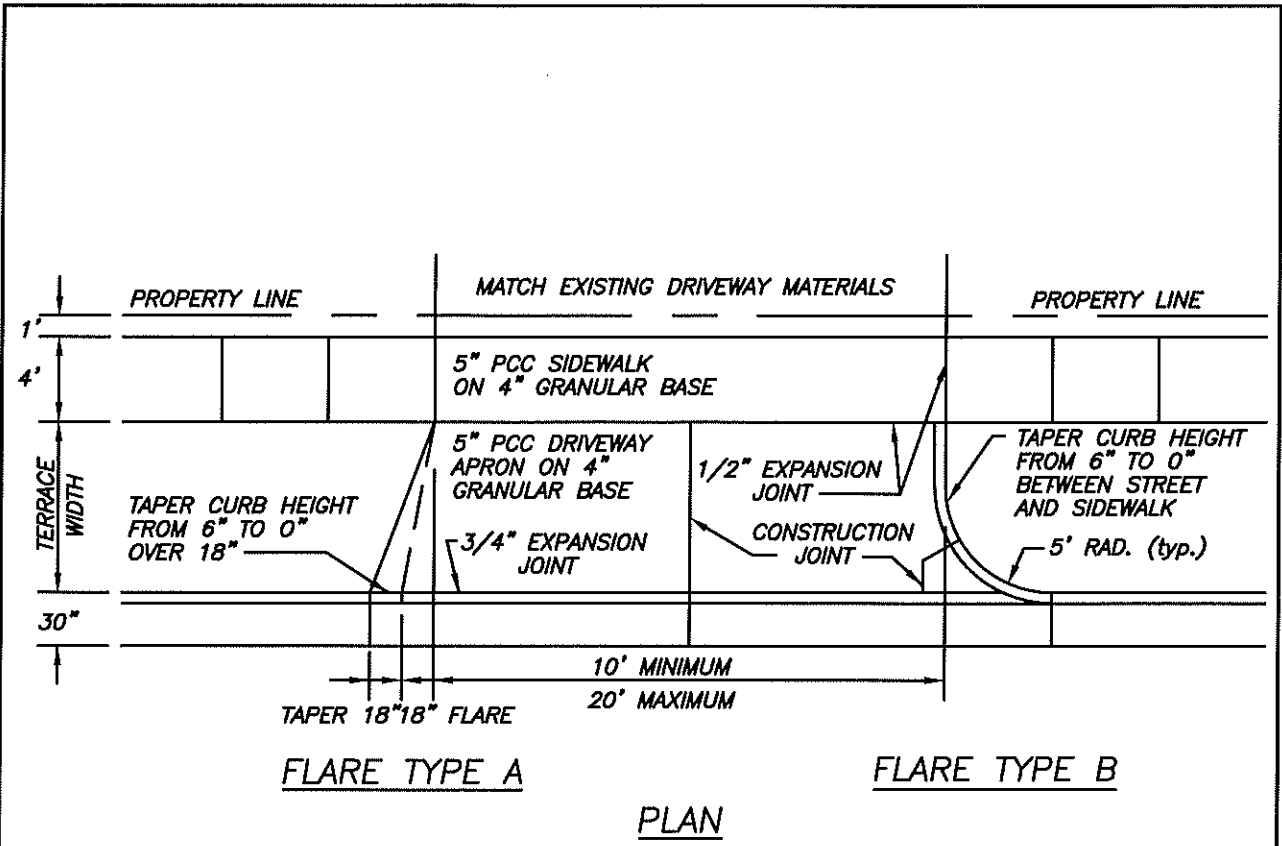

NOTES:

1. A STREET OPENING PERMIT IS REQUIRED FOR CONSTRUCTION ON EXISTING STREETS, UNLESS PART OF A CITY PROJECT.
2. ALL DRIVEWAY APRONS WIDER THAN 15' REQUIRE A CONSTRUCTION JOINT AT THE CENTERLINE.
3. FOR TYPE 'A' APRONS, EXTEND FLARE ACROSS FULL WIDTH OF TERRACE, UP TO 8' MAXIMUM. SEE ENGINEER FOR FLARE REQUIREMENTS IF TERRACE WIDTH IS LESS THAN 4'.

	<p>CITY OF MIDDLETON STANDARD DETAIL</p>
<p>RESIDENTIAL DRIVEWAY APRON</p>	
<p>REVISED DRAWN BY:</p>	<p>08-08-2014 RAW</p>
<p>600-3</p>	

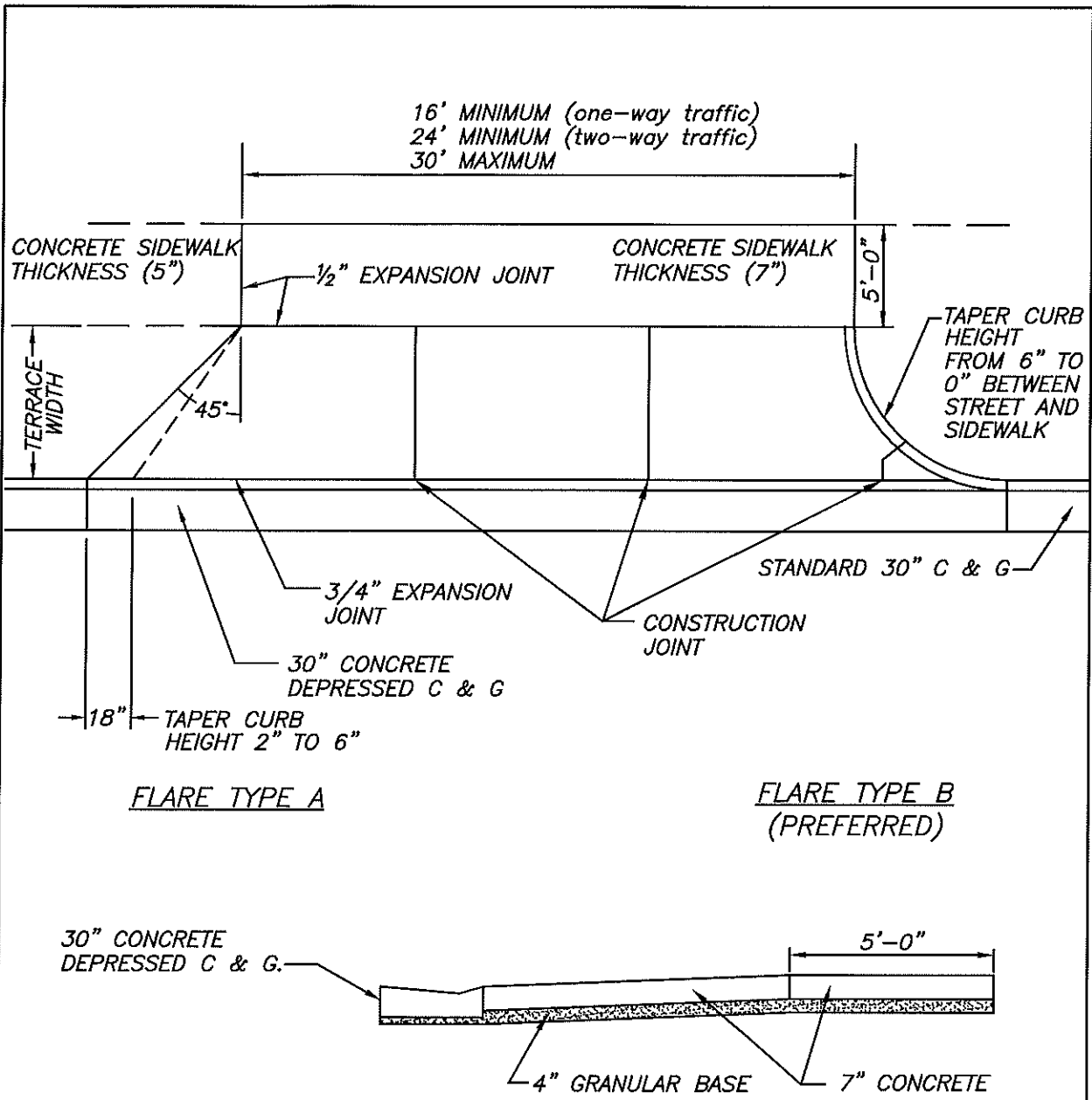

NOTES:

1. A STREET OPENING PERMIT IS REQUIRED FOR CONSTRUCTION ON EXISTING STREETS, UNLESS PART OF A CITY PROJECT.
2. ALL DRIVEWAY APRONS WIDER THAN 15' REQUIRE CONSTRUCTION JOINTS AT AN ASPECT RATIO OF 1.5 TO 1
3. FOR TYPE 'A' APRONS, EXTEND FLARE ACROSS FULL WIDTH OF TERRACE, UP TO 8' MAXIMUM. SEE ENGINEER FOR FLARE REQUIREMENTS IF TERRACE WIDTH IS LESS THAN 4'.
4. TERRACE WIDTH 7.5' MIN. TO 15' MAX.
5. TYPE B APRON RADII TO BE BETWEEN 10'-15'. IF RADIUS IS LARGER THAN TERRACE WIDTH, ENTRANCE WILL NOT BE TANGENT TO DRIVEWAY EDGE.



**CITY OF MIDDLETON
STANDARD DETAIL**

**COMMERCIAL DRIVEWAY
APRON**

REVISED
DRAWN BY:

08-08-2014
RAW

600-4

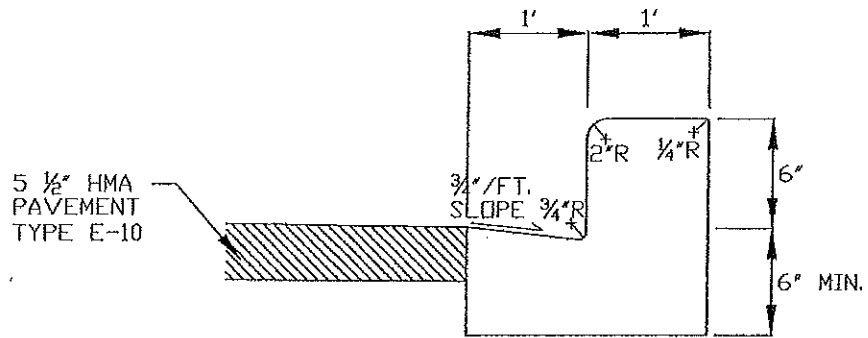

CONCRETE CURB AND GUTTER
24-INCH TYPE SPECIAL
DETAIL

NOT TO SCALE